





EXECUTIVE™ SILENT

RANGE

 Type: Liquid Cooled Diesel

 Drive: Direct

 Output: Hot Water

 Usage: Continuous

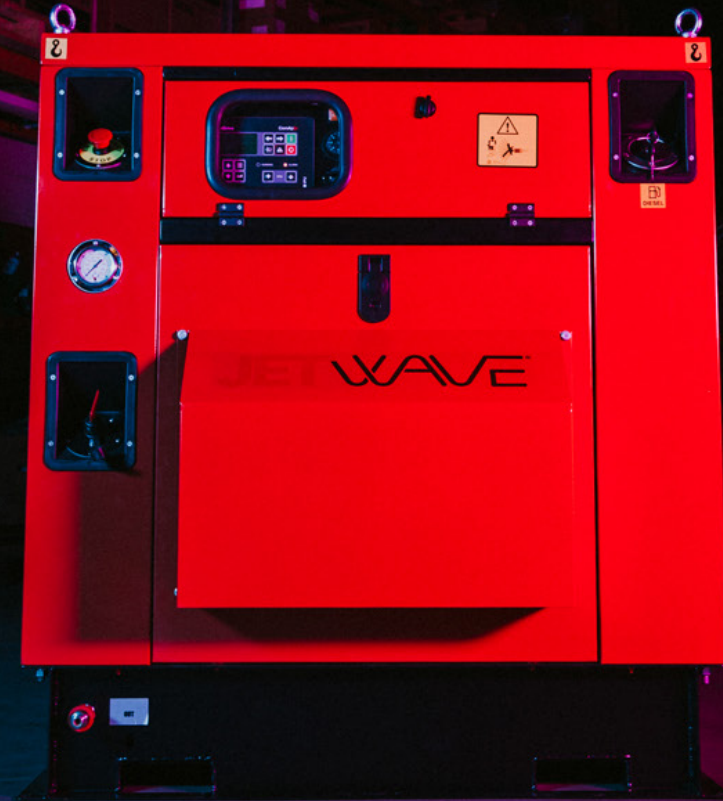

A decisive step into the future with innovation like never seen before.

JETWAVE ABOUT US VIDEO

[FIND OUT MORE](#)



EXECUTIVE™ SILENT

The Jetwave® Executive™ Silent is the ultimate hot water diesel driven pressure washer for continuous heavy duty usage. The Executive™ Silent is engineered, assembled and packed with above average features, built to last. This is the Executive™ Silent family from Jetwave®.

HERO INNOVATIONS



Ultra low noise emissions due to superior sound proof cabinet



IntelliUMS™ for full unit and operator control



Completely enclosed design to safeguard your investment



Multi Configurable to suit almost any arrangement



Oversized motor delivering the best power and performance



Centralised control for easy accessibility and versatility

MAIN FEATURES

IntelliUMS™ management system

Heavy duty inlet water filter

Triplex Italian pump

Professional accessories

12V vertical diesel burner

FIELDS OF APPLICATION

Mining Industry

Civil Construction

Aviation Ground Support

Cleaning Contractors

Government and Councils

Agricultural and Forestry

Transportation and Logistics

THE EXECUTIVE SILENT PROMISE

A revolutionary high pressure cleaning solution.

Innovation isn't just making something different, it is making it safer, easier, faster, more practical and efficient.

This cutting edge product is made specifically for high end industries such as councils and contractors. It has been designed, developed, manufactured and quality assured by a specialist team; passionate to provide the next step in high pressure equipment innovation and evolution.

Why? Because we knew things could be better. Enhanced solutions contribute to building your business through better tools. Equipment that is functional and technologically advanced to the point that its reliable day in and day out.

We aim to add more value than ever before and we guarantee a smoother application, specific installation and operational life that will yield increased return on your investment and contribute to grow your business in the area of hard surface cleaning and specialised pressure cleaning services.



EXECUTIVE™ SILENT JNR

EXECUTIVE™ SILENT



DIESEL

4060 PSI • 15 L/PM
3600 PSI • 21 L/PM



Hot Water



Continuous Usage

DIESEL

4060 PSI • 20 L/PM
4350 PSI • 21 L/PM
4350 PSI • 31 L/PM
5075 PSI • 16 L/PM
5075 PSI • 21 L/PM
7250 PSI • 18 L/PM



Hot Water



Continuous Usage



Machinery



Shipping and Marine



Trucking and Transportation

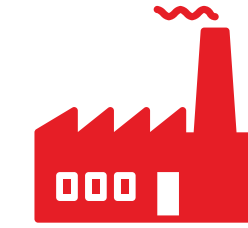

Factories and Commercial Buildings



Equipment



Mining Equipment

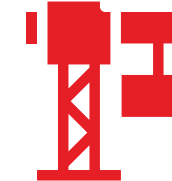

Transportation



Oil and Gas



Councils / Government Facilities



Civil Construction



Environmental Infrastructures



Industrial Cleaning



Residential



Homeowners will see investment with your professional specialised cleaning machinery. With it being a silent unit residential cleaning can be done without much hassle or noise. Add a specialist service and contribute to your businesses improved charge out rates.

Industrial

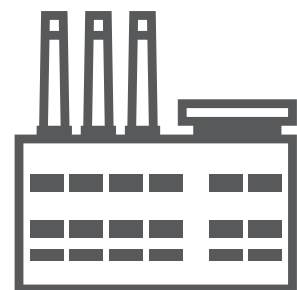

Heavy industry can produce some heavy duty waste. You need the most powerful, effective and efficient equipment to provide scope for your cleaning business. Providing a safe and silent unit combined with hot water for industrial users allows safe & powerful cleaning.

Commercial



From the local bakery to the largest commercial office buildings, the Executive Silent gets the job done powerfully and silently so you can win more jobs and get back to more business.

Municipal



Municipal cleaning; This will provide the scope to spec up or down depending on application. Again being a silent unit council cleaning can be done at all hours without much noise pollution. We aim to provide you more versatility to tender and win jobs with cost effective investment into equipment and options.

EXECUTIVE™ SILENT

A decisive step into the future of pressure washing technology with a product categorically developed for a high end commercial pressure washing professional(s).

The Executive Silent dramatically improves and revolutionises the most significant aspects of the pressure washing machine, and the overall experience.

It introduces innovative never seen before technology and capabilities on a pressure washing systems. The best performance, technology integration and life protection ever in such machinery. A range of mounting possibilities. Unified, smart LED digital display with unit protection parameters.

Enclosed steel covers provide protection from the elements for the life of your investment. Best in class low decibel output and engine load optimisation. It looks every bit as powerfully cutting edge as it is.

This is the Executive Silent.

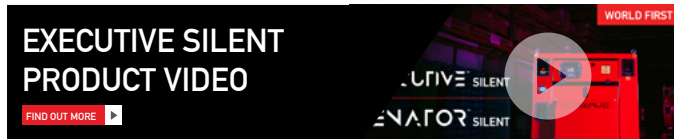



INTELIUMS™

DIGITAL, ACCURATE & INTUITIVE

This smart, industry first, IntelliUMS™ is the brains of the control centre. This LCD backlit screen provides integrated operator control, monitoring and protection for both the unit's mechanical and electrical at all times.

This new high tech protection and monitoring interface allows you to fully control and monitor the machines vital signs accurately and in real time. It displays all performance data and warning alerts on a digital display that delivers unit data to continuously optimise the working parameters and the operators experience and safeguard your investment.



BENEFITS

- 01 Key less Start / Stop.
- 02 Displays all performance data such as:
 - i Fuel tank level
 - ii Battery voltage
 - iii Running hour meter
 - iv RPM tachometer
- 03 Warning alarm set points:
 - i Service interval reminders
 - ii High temperature
 - iii Oil pressure
 - iv Low fuel level warning
 - v Battery flat detection
 - vi Load governance
 - vii Operational speed
 - viii Overcranking protection
 - ix Error log
- 04 No push or pull manual leavers / toggles.
- 05 Large LCD backlit display screen.
- 06 'Zero' power consumption mode screen.
- 07 Safeguards your investment to mitigate the risk careless operator error or misuse.
- 08 PC diagnostic input via plug.
- 9 Custom configurable.
- 10 Password protection.
- 11 USB port for programming.

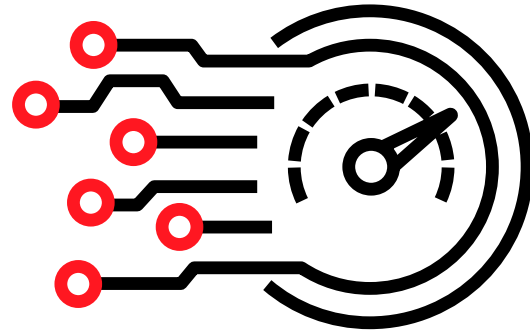

ENCLOSED DESIGN

COVER PROTECTION

Enclosed steel cover protection on a pressure washer in this class will provide the protection, safety and looks to boot. You want reliability every time and this contributes to protection from any harsh weather elements; day in day out for a long life.

BENEFITS

- 01 Made of heavy duty formed steel.
- 02 Attractive design.
- 03 Compact space saving design.
- 04 All components are reachable for maintenance / repair operation by just removing the EZYCLIP™ cover.
- 05 Top lift facility.
- 06 Longer working life of your investment.
- 07 Increases reliability of key components.
- 08 Mitigates risk of down town.
- 09 Making you more return.
- 10 Easy latch side cover for serviceability and daily checks.



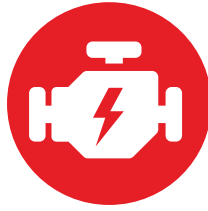

OVERSIZED MOTOR

OPTIMISING SPEEDS & LOADS

The liquid cooled diesel engine delivers some of the best power, performance and reliability in its class. With its generator style technology it optimises at all congruent engine speed and loads.

BENEFITS

- 01 Yields a decrease in fuel consumption.
- 02 Low noise, low vibration
- 03 Save on running and maintenance costs.
- 04 Meets global emission compliance.
- 05 Global parts availability and back-up service.
- 06 Optimised combustion system.
- 07 Liquid cooled for long life.

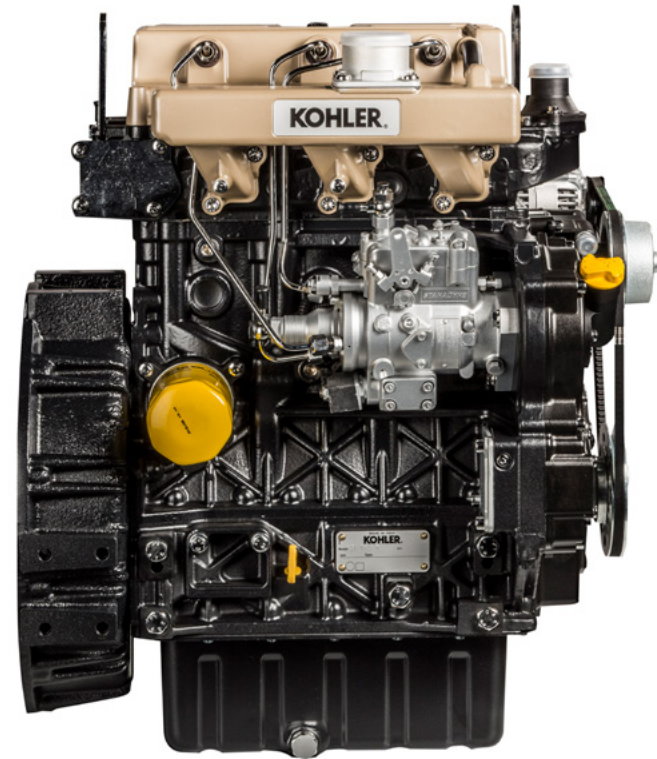

KOHLER. Diesel



ULTRA LOW DECIBEL READING

LOWER SOUND LEVELS

Ultra low noise emissions due to superior sound proof cabinet and properly enclosed design with low speed.

BENEFITS

- 01 Machine can be run continuously in built up areas.
- 02 Operator is protected from excessive noise emissions.
- 03 Continuous usage equal more jobs, increased efficiency and more income.



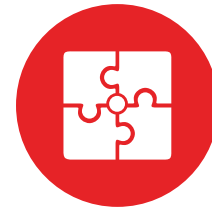

MULTI CONFIGURATION

CUSTOMISABLE & INTUITIVE

The Executive Silent can be skid, truck, or trailer mounted providing the operator with maximum mounting versatility.

BENEFITS

- 01 Spec the unit your exact way in the fleet.
- 02 Get your optimal high pressure water cleaning machine set-up the way you want it.
- 03 Increase your space and productivity by optimal vehicle layout.
- 04 Panel mounted lead hose connections.
- 05 Plug & play connections for integrated and external low level water cut-out pump protection.
- 06 No ad-hoc unit fabrication.
- 07 Better on-site maneuverability.
- 08 Transport via crane with top lift facility.
- 09 Forklift pockets integrated.

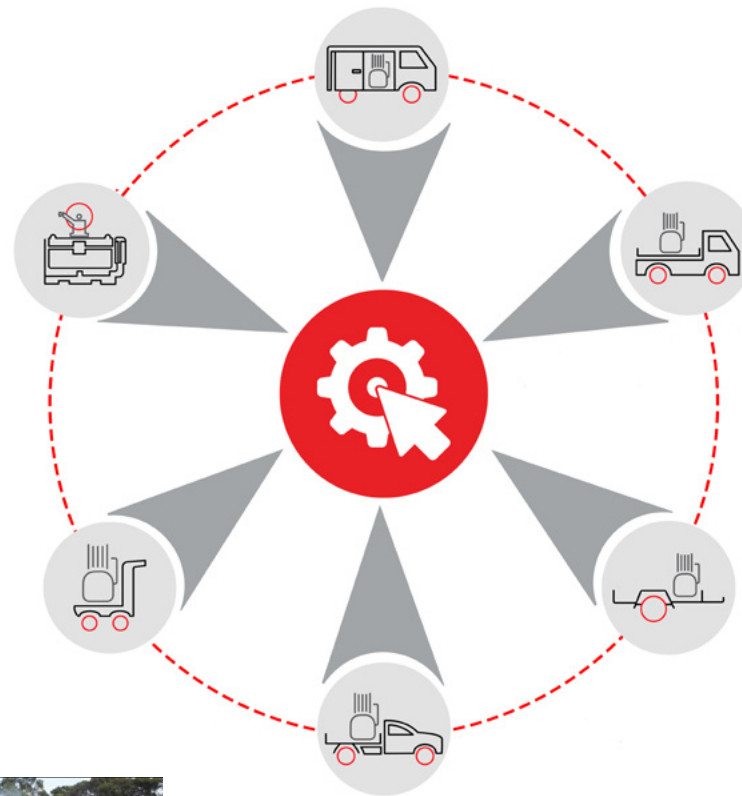

15%
LESS CUBIC SPACE
THAN THE COMPETITION

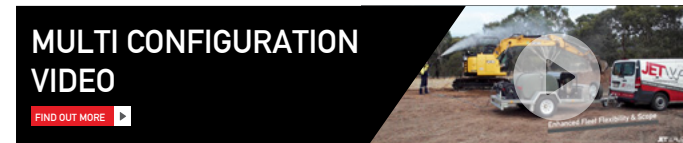

CENTRALISED CONTROL

VERSATILE & EFFECTIVE

Front facing and panel mounted controls for easy accessibility to all controls and adjustment components that ensure that equipment delivers correctly and to adapt to your job at hand in order to maximise efficiency, effectiveness and operator friendliness.

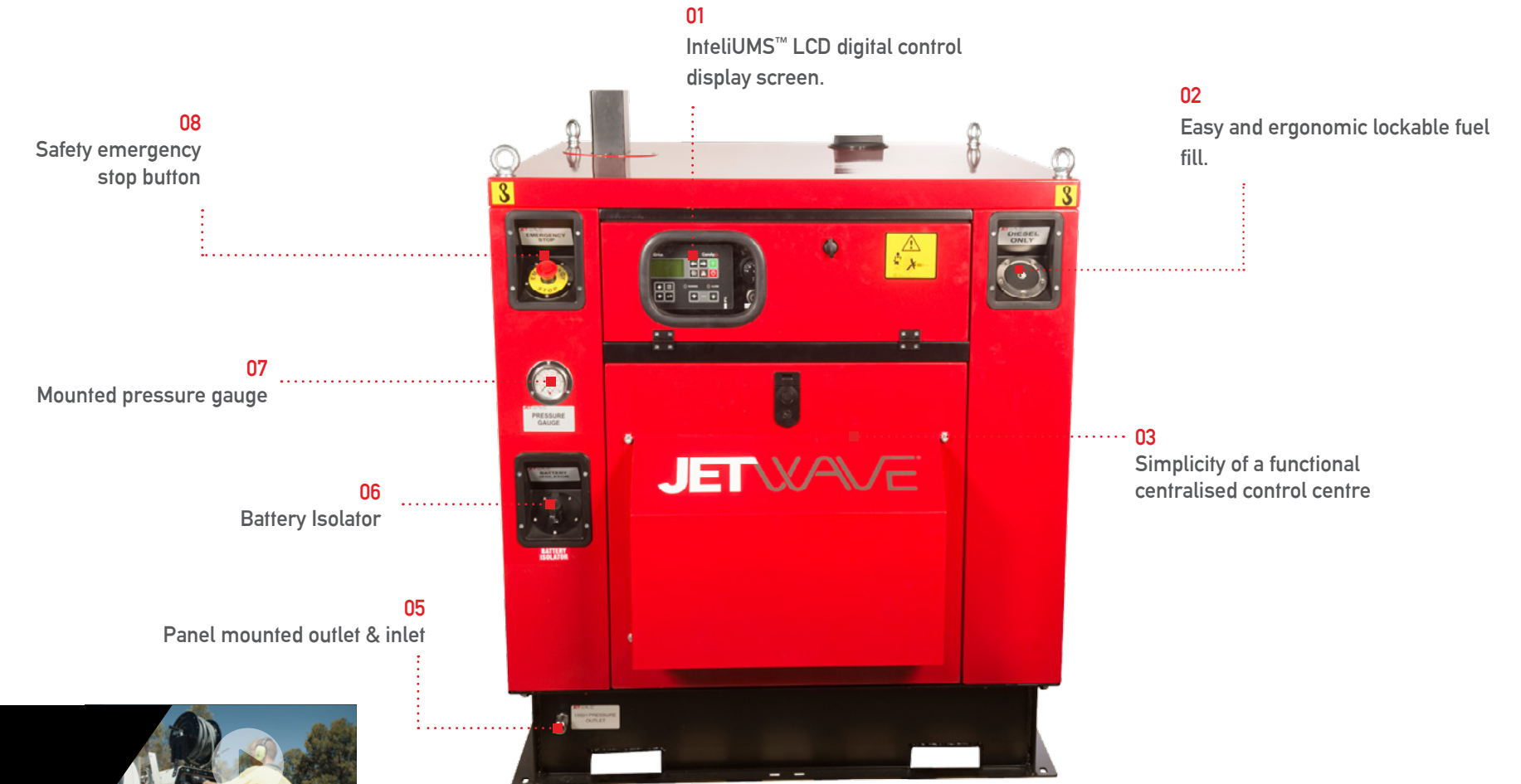

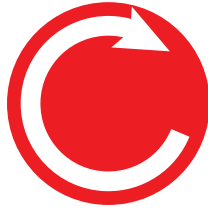

LOW SPEED TECHNOLOGY

LONGER LIFE

Low speed technology provides a physical link from pump to engine. Allowing you to get more out of your equipment putting it to work for longer ultimately effecting positively your bottom line.

BENEFITS

- 01 Optimises engine speeds at particular loads.
- 02 Extended run times.
- 03 Decreases fuel consumption.
- 04 Drastically decreased noise levels.
- 05 Less RPM's equals less maintenance costs.
- 06 Reduces emissions and exhaust gases.
- 07 Allows you to work day and night.

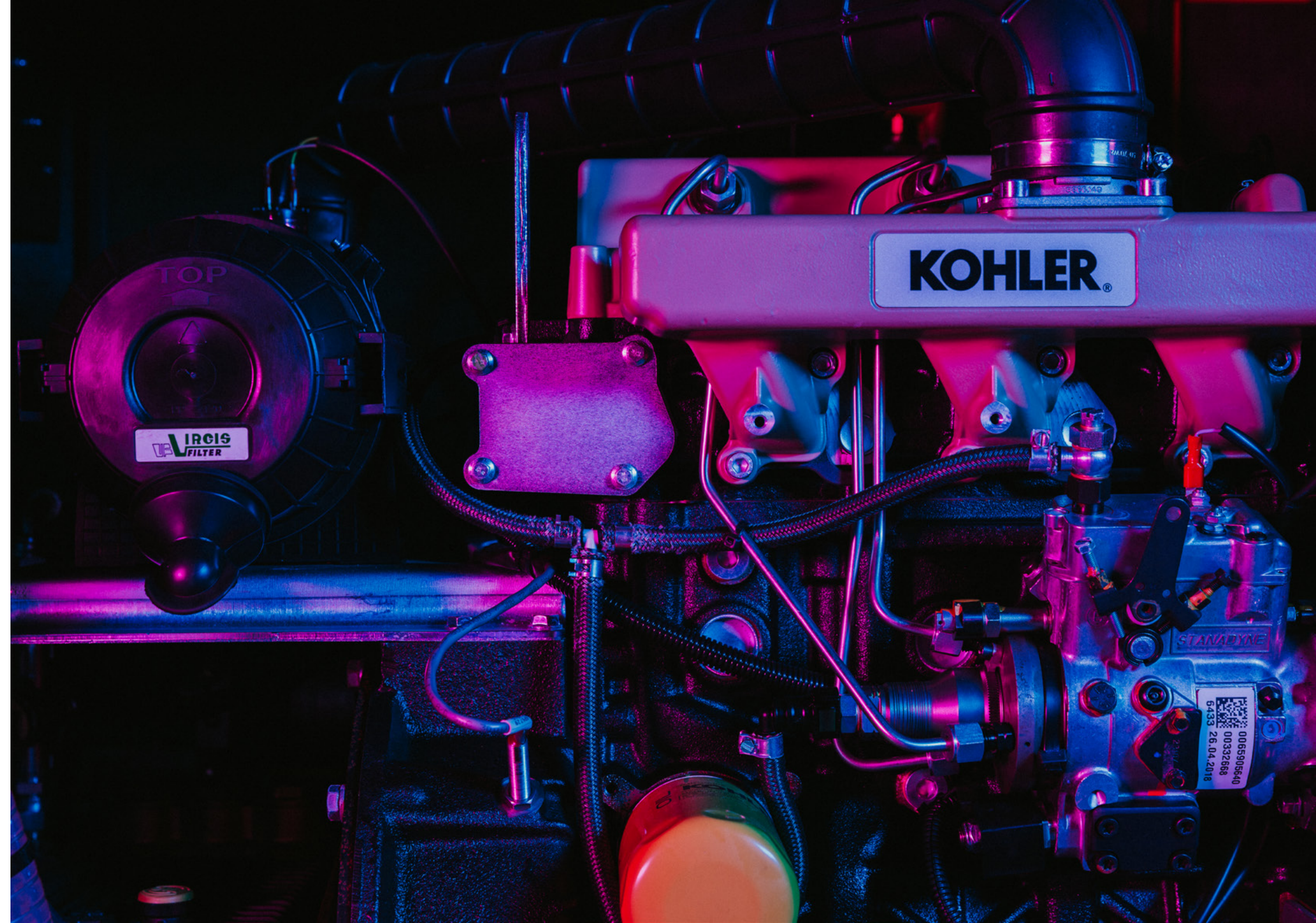
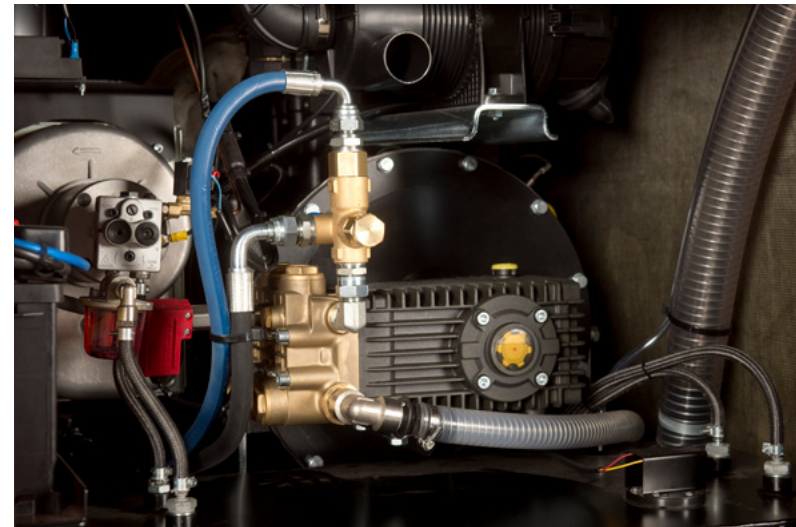

LOW SPEED TECHNOLOGY VIDEO

FIND OUT MORE



STANDOUT FEATURES



World class industrial KOHLER™ engine



Quality brass / stainless steel unloader valve



Triplex professional Italian pump delivers performance and longer life



Low speed professional pump for increased reliability and longer maintenance intervals



Easy key less start with maintenance free battery

ENGINE

Powerful and easy start diesel liquid cooled electric start engine from a global manufacturer, to assist with putting you ahead of the competition and maximise efficiency.

PUMP AND COMPONENTS

The highest quality precision Italian manufactured components with flow and pressure performance for the toughest operations.

INTELIUMS™ UNIT MANAGEMENT SYSTEM

Functional easy read digital display and unit monitoring protection to safeguard your investment.

SILENT DESIGN

Ultra low noise emissions due to superior sound proof cabinet and enclosed exhaust design with low rpm speed.

PROTECTIVE COVER

Enclosed design steel cover to safeguard the heart of your investment.

BURNER SYSTEM

90% fuel efficient environmentally friendly 12V vertical diesel fired hot water burner system.

PRESSURE GAUGE

Accurate pressure gauge.



STANDOUT FEATURES



NEW Vertical 90% fuel efficient environmentally friendly diesel fired hot water burner system



12V Advanced Burner Control



Jetwave Safety System™ (JSS) over pressurisation



Heavy duty washable inlet water filter



Emergency stop protection

TOP LIFT

4 x top lifting lugs for transportation via crane.

SAFETY FIRST

Emergency Stop button for user safety.

DIESEL TANK

Easy to fill integrated diesel tank.

ANTI-VIBRATION SYSTEM

Exclusive to Jetwave this boasts life expediency and ensures a longer machine life.

LOW LEVEL WATER CUT OUT

To ensure pump anti-run dry protection at all times.

INTEGRATED

Bunded oil tray and forklift pockets.

PAYBACKS IN INNOVATION YOU CAN TAKE TO THE BANK

Operator safety and functionality greater than ever before.

Reduce expenses and downtime.

Choice of performance and size.

Improve productivity and job site safety.

Increase runtime.

Optimise space via configurations, meaning more room in your van, truck or work trailer for other job site tools and equipment.

Decreased risk of operator error.

Maintenance costs squeezed.

Lower cost of ownership long term.

More environmentally friendly.

Product longevity.

Investment protected.

Jobs done faster, safer and more efficient.

Versatility across mounting/vehicle configurations to provide space savings.

Decreased noise levels:

- Less engine noise means clearer communication onsite.
- Can be used earlier and later in noise sensitive environment so more work can get done.

Maintain integrated unit monitoring for warning and performance data.



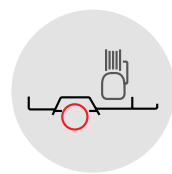

TRAILER MOUNT

SEAMLESSLY MOUNT YOUR WAY.

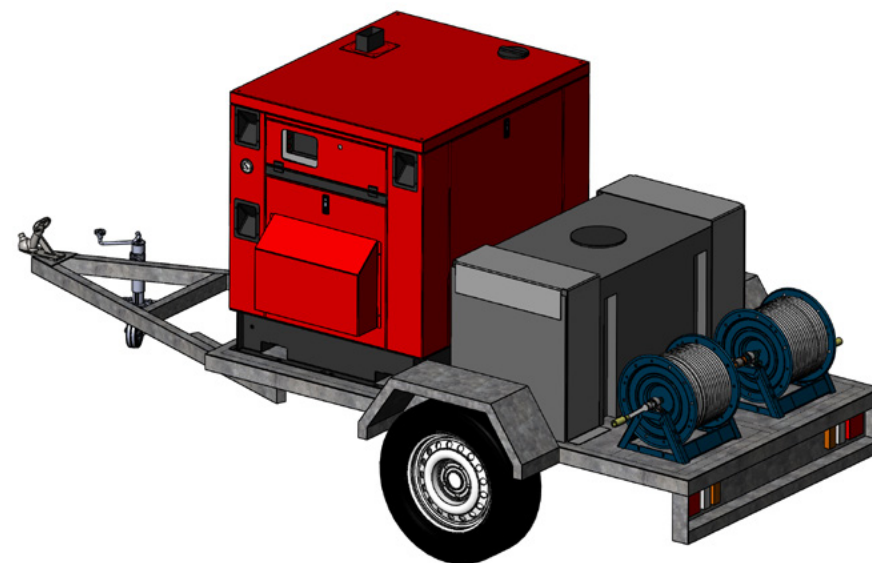

Single Axle Trailer
600L Water Tank

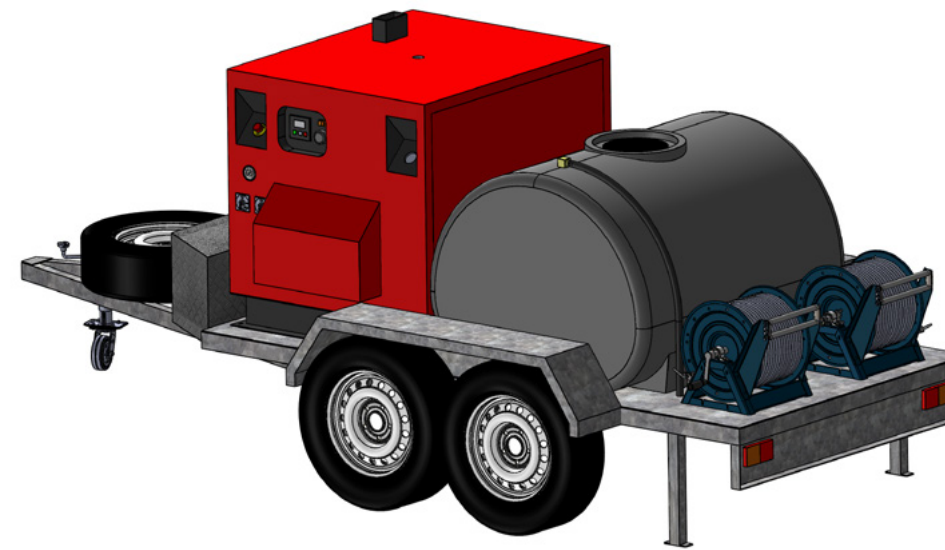

Tandem Axle Trailer Mount
1000L Water Tank

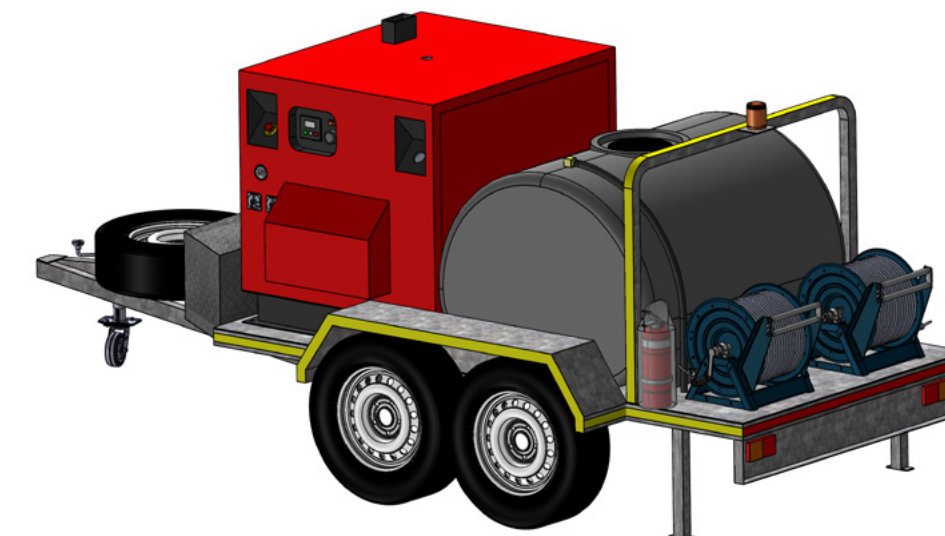

Tandem Axle Trailer Mount Mine Spec
1000L Water Tank

STANDARD EQUIPMENT INCLUDED

200-300 BAR EQUIPMENT



J5000 DUROTECH GUN



Ergonomic J5000™ Durotech™ Gun heavy duty spray gun with back part lance and centre quick coupling.

P/N: JW5000

TWIN LANCE



Twin Lance with variable pressure adjustment with stainless steel hardened nozzle.

P/N: 41091900-04

DWB HOSE



15m of 3/8" double wire braided hose with quick coupling.

P/N: JWA017

500 BAR EQUIPMENT

500 BAR GUN & STAINLESS STEEL LANCE



500 Bar gun & stainless steel lance.

P/N: TBC

500 BAR DWB HOSE



10m of 3/8" DWB 500 Bar hose with m24 quick coupling.

P/N: TBC

OPTIONAL MACHINE UPGRADES

350 BAR EQUIPMENT

350 BAR GUN & STAINLESS STEEL LANCE



Industrial duty with low pull force trigger & Stainless steel single lance with hardened nozzle and protector and 15m of 3/8" DWB hose

P/N: TBC

INCLUDED MACHINE UPGRADES

FORKLIFT POCKETS, BATTERY ISOLATOR, EMERGENCY STOP & TOP LIFT



Included upgrades on Executive Silent Jnr & Executive Silent

OPTIONAL MACHINE UPGRADES

LED WORK LIGHTS & BEACON



LED Work lights and beacon light.

P/N: JWA-427

MINE SPEC UPGRADE



Mine specification kit.

P/N: MINE-KIT1



TURBO HEAD WITH LANCE



Complete turbo head with lance for increased cutting power.

P/N: JWA160



LS12 FOAMING KIT



LS12 Foaming lance with tank.
P/N: JWA221-LS12



GIRAFFE™ TELESCOPIC LANCE



Alloy telescopic lance (7m) to reach high places

P/N: DCLTG24A4

ADDITIONAL HOSE



Extra high pressure hose per metre.
P/N: 52001



HAMMERHEAD FSC 21" - ABS PLASTIC



21" Flat surface cleaner for large surface areas.
P/N: JWA-FSC21



HAMMERHEAD FSC 21" - STAINLESS STEEL



21" Stainless Steel flat surface cleaner for large surface areas.
P/N: JWA-FSC22



HAMMERHEAD FSC 30" - STAINLESS STEEL



30" Stainless Steel Flat surface cleaner for larger surface areas.
P/N: JWA-FSC30

SLUDGE KIT



Sludge kit to remove water from areas.
P/N: 80005

APACHE A-FRAME HOSE REEL



High pressure hose reel with 120m capacity of 3/8" hose. Optional double stack kit available & optional hose reel guide

P/N: JWA120
DOUBLE STACKED P/N: JWA120-DSK
HOSE REEL GUIDES P/N: 2100503/H

TST PPE 500BAR SAFETY PACK



Safety vest, pants, boots, coat, helmet, hearing and visor.

P/N: 1067CMLSS



SANDBLASTING KIT



Use sand to cut different material surfaces, eg stripping paint.

P/N: JWA164



PRO FOAM KIT



Professional foaming kit for chemical cleaning.

P/N: PROFOAM



Product Code	p/n	HW4000-15DI	HW3600-21DI	HW4000-20DI	HW4350-21DI	HW4350-31DI
TECHNICAL DATA						
Working Pressure	psi / bar	4060 / 280	3600 / 250	4060 / 280	4350 / 300	4350 / 300
Flow Rate	l/pm / l/ph	15	21	20	21	31
Cleaning Units (CU)	psi x l/pm	60,900	75,600	81,600	100,050	134,850
Max Water Inlet Temp	°c / °f	60 / 140	60 / 140	60 / 140	60 / 140	60 / 140
Class (AS/NZS 4233:2013)	grade	A (4,200 BAR/LITRES)	A (5,250 BAR/LITRES)	A (5,600 BAR/LITRES)	B (6,900 BAR/LITRES)	B (9,300 BAR/LITRES)

INTENDED APPLICATION						
Usage	hours	8-12 daily	8-12 daily	8-12 daily	8-12 daily	8 - 12 daily
Category of Dirt / Debris	type	Medium	Medium	Medium	Heavy	Heavy

MOTOR FEATURES						
Engine	type	KOHLER™ (4 stroke, water cooled)	KOHLER™ (4 stroke, water cooled)	KOHLER™ (4 stroke, water cooled)	KOHLER™ (4 stroke, water cooled)	KOHLER™ (4 stroke, water cooled)
Fuel Supply	type	Diesel	Diesel	Diesel	Diesel	Diesel
Fuel Capacity	litres	100	100	100	100	100
Low Oil Shutdown	y / n	Y	Y	Y	Y	Y
Hour Meter	y / n	Y (standard)	Y (standard)	Y (standard)	Y (standard)	Y (standard)
Starting System	type	InteliUMS™ Push Button Start	InteliUMS™ Push Button Start	InteliUMS™ Push Button Start	InteliUMS™ Push Button Start	InteliUMS™ Push Button Start

HYDRAULIC FEATURES						
Pump / Head / Pistons	type	JW Plunger Triplex / Brass / Ceramic	JW Plunger Triplex / Brass / Ceramic	JW Plunger Triplex / Brass / Ceramic	JW Plunger Triplex / Brass / Ceramic	JW Plunger Triplex / Brass / Ceramic
Motor Pump Coupling	type	Direct Soft Coupling	Direct Soft Coupling	Direct Soft Coupling	Direct Soft Coupling	Direct Soft Coupling
RPM	rpm	1500	1500	1500	1500	1500
Unloader Valve	type	Independent	Independent	Independent	Independent	Independent
Safety Valve	y / n	Y	Y	Y	Y	Y

Orifice / Nozzle	size	040	065	055	055	035
------------------	------	-----	-----	-----	-----	-----

THERMAL FEATURES						
Burner Model	type	Vertical	Vertical	Vertical	Vertical	Vertical
Fuel Supply	type	Diesel	Diesel	Diesel	Diesel	Diesel
Fuel Tank Capacity	litres	70 (Common)	70 (Common)	70 (Common)	100 (Common)	100 (Common)
Burner Fuel Consumption (max)	litres	5.74	5.74	5.74	6.55	6.55
Coil	type	Mild steel 3mm wall seamless	Mild steel 3mm wall seamless	Mild steel 3mm wall seamless	Hi-flow mild steel 3mm wall seamless	Hi-flow mild steel 3mm wall seamless
Housing Material	type	Steel	Steel	Steel	Steel	Steel

OTHER FEATURES						
Adjustable Pressure	y/n	N	N	N	N	N
Frame Structure	type	Zinc annealed powder coated cabinet with removable side covers	Zinc annealed powder coated cabinet with removable side covers	Zinc annealed powder coated cabinet with removable side covers	Zinc annealed powder coated cabinet with removable side covers	Zinc annealed powder coated cabinet with removable side covers
Onboard Accessory Storage	y / n	N	N	N	N	N
Detergent Injector	y / n	N	N	N	N	N

WARRANTY(S)						
Motor Warranty	years	3 KOHLER Diesel	3 KOHLER Diesel	3 KOHLER Diesel	3 KOHLER Diesel	3 KOHLER Diesel
Unit Warranty	years	2 	2 	2 	2 	2 

DIMENSIONS & WEIGHT						
Approx Weight	kg	568 unit / POA boxed	568 unit / POA boxed	568 unit / POA boxed	633 unit / POA boxed	633 unit / POA boxed
Unit Dimensions	mm	1730(L) x 1230(W) x 1480(H)	1730(L) x 1230(W) x 1480(H)	1730(L) x 1230(W) x 1480(H)	1730(L) x 1230(W) x 1480(H)	1730(L) x 1230(W) x 1480(H)
Boxed Dimensions	mm	1760(L) x 1260(W) x 1510(H)	1760(L) x 1260(W) x 1510(H)	1760(L) x 1260(W) x 1510(H)	1760(L) x 1260(W) x 1510(H)	1760(L) x 1260(W) x 1510(H)
Number per Pallet	pieces	Custom: 1	Custom: 1	Custom: 1	Custom: 1	Custom: 1

*Coverage against defects in material and workmanship (refer to Jetwave Warranty Terms and Conditions). The manufacturer reserves the right to modify design features and technical facts without notice, due to our principals of continuous improvement.

RANGE BUILD-UP

EXECUTIVE SILENT EXECUTIVE SILENT EXECUTIVE SILENT

Product Code	p/n	HW5000-16DI	HW5000-23DI	HW7250-18DI
TECHNICAL DATA				
Working Pressure	psi / bar	5075 / 350	5075 / 350	7250 / 500
Flow Rate	l/pm / l/ph	16	23	18
Cleaning Units (CU)	psi x l/pm	81,200	116,725	130,500
Max Water Inlet Temp	°c / °f	60 / 140	60 / 140	60 / 140
Class (AS/NZS 4233:2013)	grade	A (5,600 BAR/LITRES)	B (8,050 BAR/LITRES)	B (9,000 BAR/LITRES)

INTENDED APPLICATION

Usage	hours	8-12 daily	8-12 daily	8-12 daily
Category of Dirt / Debris	type	Heavy	Heavy	Heavy

MOTOR FEATURES

Engine	type	KOHLER™ (4 stroke, water cooled)	KOHLER™ (4 stroke, water cooled)	KOHLER™ (4 stroke, water cooled)
Fuel Supply	type	Diesel	Diesel	Diesel
Fuel Capacity	litres	100	100	100
Low Oil Shutdown	y / n	Y	Y	Y
Hour Meter	y / n	Y (standard)	Y (standard)	Y (standard)
Starting System	type	InteliUMS™ Push Button Start	InteliUMS™ Push Button Start	InteliUMS™ Push Button Start

HYDRAULIC FEATURES

Pump / Head / Pistons	type	JW Plunger Triplex / Brass / Ceramic	JW Plunger Triplex / Brass / Ceramic	JW Plunger Triplex / Brass / Ceramic
Motor Pump Coupling	type	Direct Soft Coupling	Direct Soft Coupling	Direct Soft Coupling
RPM	rpm	1500	1500	1500
Unloader Valve	type	Independent	Independent	Independent
Safety Valve	y / n	Y	Y	Y

RANGE BUILD-UP cont.

Orifice / Nozzle	size	040	040	065
------------------	------	-----	-----	-----



THERMAL FEATURES

Burner Model	type	Vertical	Vertical	Vertical
Fuel Supply	type	Diesel	Diesel	Diesel
Fuel Tank Capacity	litres	100 (Common)	100 (Common)	100 (Common)
Burner Fuel Consumption (max)	litres	5.74	5.74	5.74
Coil	type	Mild steel 3mm wall seamless	Mild steel 3mm wall seamless	Mild steel 3mm wall seamless
Housing Material	type	Steel	Steel	Steel

OTHER FEATURES

Adjustable Pressure	y/n	N	N	N
Frame Structure	type	Zinc annealed powder coated cabinet with removable side covers	Zinc annealed powder coated cabinet with removable side covers	Zinc annealed powder coated cabinet with removable side covers
Onboard Accessory Storage	y / n	N	N	N
Detergent Injector	y / n	N	N	N

WARRANTY(S)

Motor Warranty	years	3 KOHLER Diesel	3 KOHLER Diesel	3 KOHLER Diesel
Unit Warranty	years	2 	2 	2 

DIMENSIONS & WEIGHT

Approx Weight	kg	633 unit / POA boxed	633 unit / POA boxed	633 unit / POA boxed
Unit Dimensions	mm	1730(L) x 1230(W) x 1480(H)	1730(L) x 1230(W) x 1480(H)	1730(L) x 1230(W) x 1480(H)
Boxed Dimensions	mm	1760(L) x 1260(W) x 1510(H)	1760(L) x 1260(W) x 1510(H)	1760(L) x 1260(W) x 1510(H)
Number per Pallet	pieces	Custom: 1	Custom: 1	Custom: 1

*Coverage against defects in material and workmanship (refer to Jetwave Warranty Terms and Conditions). The manufacturer reserves the right to modify design features and technical facts without notice; due to our principals of continuous improvement.

@jetwave.group
#imagineCLEAN
#JetwaveSilentSeries



📍 10 - 16 Smith Street | Thebarton | Adelaide | South Australia | 5031 | AU
☎ +61 8 8371 3599 | ✉ sales@jetwave.com.au | 🌐 jetwavegroup.com



V2.0 08/2020

Jetwave® and Executive Silent™ are registered trademarks of Jetwave® Group Pty Ltd.

Distributed by:

For more information on our products, please visit jetwavegroup.com