

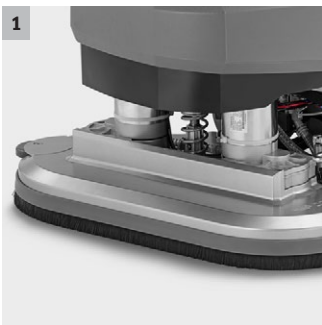

## BD 70/75 W Classic Bp

BD 70/75 W Classic Bp push scrubber drier with 75-litre tank and dual-disk brush head. Very easy to use and extremely versatile.



### 1 The brush head and squeegee are made from long-lasting aluminium

- Robust machine concept for tough working conditions with low failure rates.
- Also developed for applications in harsh conditions.

### 2 Extremely simple operating concept

- All machine functions can be operated using switches, buttons and knobs.
- Colour-coded controls for easy operation and short teach-in times.

### 3 Compact and robust design

- Highly versatile, easy to manoeuvre machine that provides a good overview.
- Reduces the risk of damaging the machine or equipment.

### 4 Brush contact pressure can be adjusted as needed

- Contact pressure can be increased from 30 to 50 kilograms as needed.
- Lower contact pressure when there is only a little dirt or if the floor is delicate.



## BD 70/75 W Classic Bp

- Extremely robust and durable components for tough applications
- Very simple, intuitive operating concept
- With tried-and-tested disc brush engineering (double disc)

### Technical data

<b>Order no.</b>	1.127-013.0	
<b>EAN code</b>	4054278482736	
<b>Working width of brushes</b>	mm	705
<b>Working width, vacuuming</b>	mm	1030
<b>Max. area performance</b>	m <sup>2</sup>	3195
<b>Fresh/dirty water tank</b>	l	75 / 75
<b>Brush contact pressure</b>	g/cm <sup>2</sup> / kg	20.4 - 34 / 30 - 50
<b>Brush speed</b>	rpm	180
<b>Rated input power</b>	W	max. 1850
<b>Weight (with accessories)</b>	kg	110
<b>Dimensions (L × W × H)</b>	mm	1445 × 750 × 1065
<b>Battery voltage</b>	V	24

### Equipment

<b>Disc brush</b>	■
<b>Fact</b>	-
<b>Tin</b>	-
<b>Powerful traction drive</b>	■
<b>squeegee, angled</b>	■

■ Included in the scope of supply.

# BD 70/75 W CLASSIC BP

## 1.127-013.0

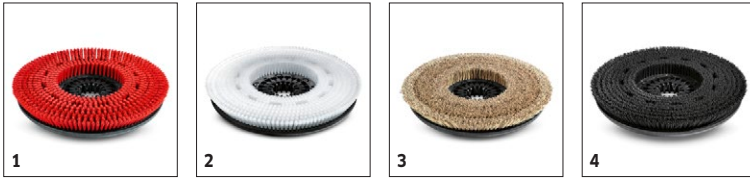

		Order no.	Hardness / Brush type	Diameter	Colour	Quantity	Price	Description	
<b>Disc brushes</b>									
Disc brush	1	4.905-010.0	medium	355 mm	red	1 piece(s)		Red standard disc brush for regular maintenance cleaning.	<input checked="" type="checkbox"/>
	2	4.905-011.0	very soft	355 mm	White	1 piece(s)		White, soft disc brush for the gentle cleaning of sensitive floor coverings.	<input type="checkbox"/>
	3	4.905-012.0	soft	355 mm	natural	1 piece(s)		Natural-coloured, soft disc brush for cleaning and polishing textured floor coverings.	<input type="checkbox"/>
	4	4.905-013.0	hard	355 mm	black	1 piece(s)		Black, very abrasive disc brush for the deep cleaning of hard-wearing floor coverings with very sticky dirt.	<input type="checkbox"/>

■ Included in the scope of supply. □ Available accessories.

# BD 70/75 W CLASSIC BP 1.127-013.0

**KÄRCHER**

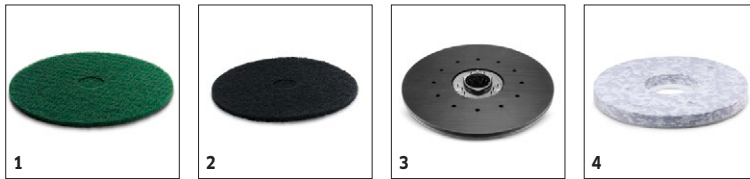

		Order no.	Hardness / Brush type	Diameter	Colour	Quantity	Price	Description	
<b>Pads</b>									
Pad	1	6.369-002.0	medium-hard	356 mm	green	5 piece(s)		Green, abrasive roller pad for deep cleaning, as well as the removal of sticky dirt.	<input type="checkbox"/>
	2	6.369-001.0	hard	356 mm	black	5 piece(s)		Black, very abrasive disc pad for the deep cleaning of hard-wearing floor coverings with very sticky dirt.	<input type="checkbox"/>
<b>Pad drive boards</b>									
Pad drive board STRONG	3	4.762-590.0		335 mm		1 piece(s)		Required for use of melamine pads, but can also be used for normal pads. Pad drive board with lots of extra hooks for holding pads. Extra-strong hold of the pad at the pad drive board of the cleaning head D 65. 2 pc. required.	<input type="checkbox"/>
<b>Melamine pads</b>									
Melamine pad	4	6.371-021.0		356 mm	Grey/ white	2 piece(s)		White melamine disc pad for intermediate and deep cleaning of microporous surfaces, as well as fine stone and other hard floor coverings. Can also be used for removing grey haze.	<input type="checkbox"/>

■ Included in the scope of supply. □ Available accessories.

# BD 70/75 W CLASSIC BP

## 1.127-013.0

**KÄRCHER**

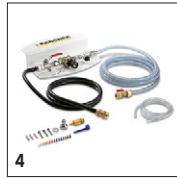

		Order no.	Length	Colour	Quantity	Price	Description	
<b>Home Base accessories</b>								
Home Base mop holder kit	1	9.753-023.0			1 piece(s)		Holder fits on machine for convenient wiping mop storage.	<input type="checkbox"/>
Universal hook kit	2	4.070-075.0			1 piece(s)		Hook and adaptor kit for attachment to the Home Base rail scrubber drier by Kärcher. Ideal for space-saving storage of hoses (for example, spray suction attachment kit) on the machine.	<input type="checkbox"/>
Holder for squeegee	3	9.753-088.0			1 piece(s)		Holder for squeegee: The steel holder is attached to the Home Base rail of the scrubber drier and allows the safe storage and transportation of the squeegee.	<input type="checkbox"/>
<b>Dosing aids</b>								
DS 3 Cleaning Agent Dosing Station	4	2.641-811.0			1 piece(s)		After connecting to a tap, cleaning agent can be filled into the fresh water tank and diluted as required. Can also be used with the filling system attachment kit. Includes back-flow preventer (DIN EN 1717).	<input type="checkbox"/>

■ Included in the scope of supply. □ Available accessories.

# BD 70/75 W CLASSIC BP

## 1.127-013.0



2

		Order no.	Length	Diameter	Quantity	Price	Description	
<b>Other attachment kits</b>								
Attachment kit for emergency off button	1	2.644-139.0			1 piece(s)		Attachment kit for attaching an emergency off button, which when pressed stops the scrubber drier completely. Simple reset of the button to resume operation.	<input type="checkbox"/>
Attachment kit stacked bumper roller squeegee	2	4.035-619.0			2 -part		Additional, non-marking bumper rollers for assembly at the ends of the squeegee. Effectively prevent the squeegee from hooking onto pallets or shelf feet.	<input type="checkbox"/>
<b>Lighting / revolving signal light mounting kit</b>								
Flashing beacon	3	2.644-140.0			1 piece(s)		Non-glare flashing beacon increases safety when working in dark buildings.	<input type="checkbox"/>

■ Included in the scope of supply. □ Available accessories.

# BD 70/75 W CLASSIC BP 1.127-013.0



		Order no.	Quantity	Battery voltage	Battery capacity	Battery type	Price	Description	
<b>Batteries</b>									
Battery kit	1	2.815-092.0	4 -part	24 V	170 Ah	mainte-nance-free		Battery kit with 24 V voltage and 170 Ah (C5) capacity. Comprising several maintenance-free single AGM batteries.	<input type="checkbox"/>
	2	2.815-091.0	2 -part	24 V	115 Ah	mainte-nance-free		Battery kit with 24 V voltage and 115 Ah (C5) capacity. Comprising several maintenance-free single AGM batteries.	<input type="checkbox"/>
<b>Battery Chargers</b>									
Battery charger	3	4.654-012.0	1 piece(s)	24 V		separate		24 V battery charger, specifically for 24 V battery set (Order No. 4.035-388.0) with 170 Ah storage capacity.	<input type="checkbox"/>
<b>Accessories for batteries</b>									
Battery mounting kit	4	2.638-162.0	3 -part					Installation kit for installing battery kit in a machine. Incl. 3 connection cables.	<input type="checkbox"/>
	5	2.638-198.0	3 -part					Installation kit for installing battery kit in a machine. Incl. 1 connection cable and 2 brackets.	<input type="checkbox"/>

■ Included in the scope of supply. □ Available accessories.